

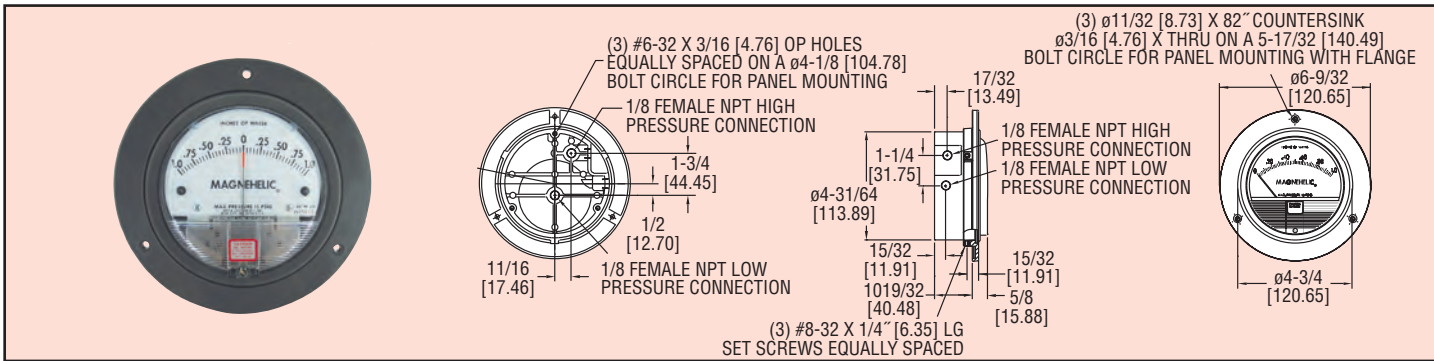

Model
A-286

Magnehelic[®] Gage Panel Mounting Flange

Flange for Panel Mounting 4-1/2" Diameter Gages



The new mounting flange can be used on any Dwyer Instruments, Inc. gage that possesses a 4-1/2" (115 mm) diameter housing. The flange is secured to the gage behind its bezel with three set screws. The set screws hold the gage tight in place. The gage/flange can then be quickly attached to a surface or panel with a drill and the supplied mounting screws. The flange's three mounting holes follow the industry standard mounting pattern. The flange is made of a robust plastic composite and comes with three pre-installed set screws, an allen wrench for tightening and three flange mounting screws.

SPECIFICATIONS

Flange Materials: Plastic.

Weight: 2.3 oz (65 g).

INCLUDED ACCESSORIES

3 Pre-installed metal set screws

3 Mounting screws

1 Allen wrench

1 Instruction manual with mounting template

Model A-286