



MODEL FC-1000

ELECTRONIC FAN SPEED CONTROL

Low Cost, 0-10 VDC Input, Selectable Hard Start



PROCESS CONTROL

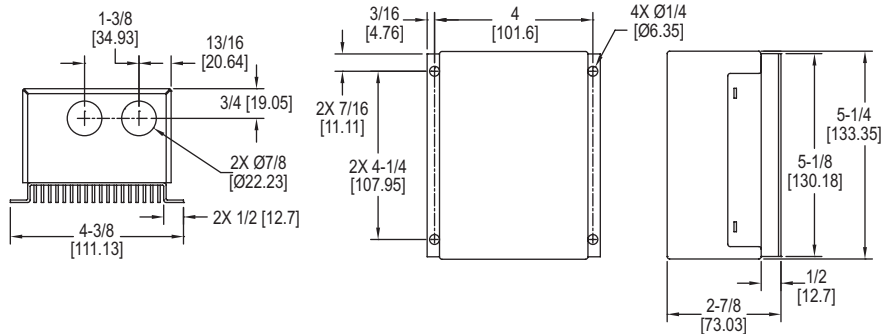

The **Model FC-1000 Electronic Fan Speed Control** provides precise speed modulation of small AC motors. Popular 0-10 VDC input works with most process controllers, eliminating the need for more expensive dampers, damper actuators, and linkages while improving overall energy efficiency of the system. This inexpensive unit enables variable control ventilation fans, condenser fans, and interfacing with VAV box controllers.

FEATURES/BENEFITS

- Compact design allows for use in most areas
- Improves energy efficiency in systems

APPLICATIONS

- Monitoring fans and motors

MODEL CHART	
Model	Description
FC-1000	Electronic fan speed control

SPECIFICATIONS

Line Voltage Range: 120-277 VAC, 60 Hz.

Input Signal Voltage: 0-10 VDC.

Low Voltage Input: 24 VAC, class 2.

Input Signal Impedance: 10K Ω.

Full Load Amp Rating: 9.8 @120 VAC, 9.3 @ 208 VAC, 8.0 @ 240 VAC, 6.9 @ 277 VAC.

Locked Rotor Amp Rating: 24.0.

Temperature Limits: -40 to 131°F (-40 to 55°C).

Electrical Connections: Line voltage: 10-32 screw terminals. Signal and low voltage input: 1/4" quick connects.

Transient Protection: 320 V surge suppression. Exceeds IEEE C62.41 standards.

Housing Materials: Cold rolled steel.

Enclosure Rating: NEMA 1.

Mounting: Vertical only; four holes provided for #10 screws.

Weight: 1 lb 11 oz (.77 kg).

Agency Approvals: UR.